



HUSH SYSTEM



SEAMLESS LOOK



GREASE COLLECTORS



PROFESSIONAL PERFORMANCE



HEAT GUARD

ELICA'S EXCLUSIVE PLUS FEATURES

Scanno available in 28", 34" & 46" sizes and with only 15 5/8" depth make it perfect to discreetly mount it inside any slim cabinet.

While having a powerful performance of 600 and 1200 CFM blower for extraordinary ventilating power. Plus the All-In-One design avoids the need to purchase a stainless liner. Hidden metallic in/out knob controls operate the 4-speed blower and LED Lighting.

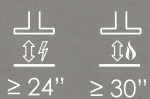
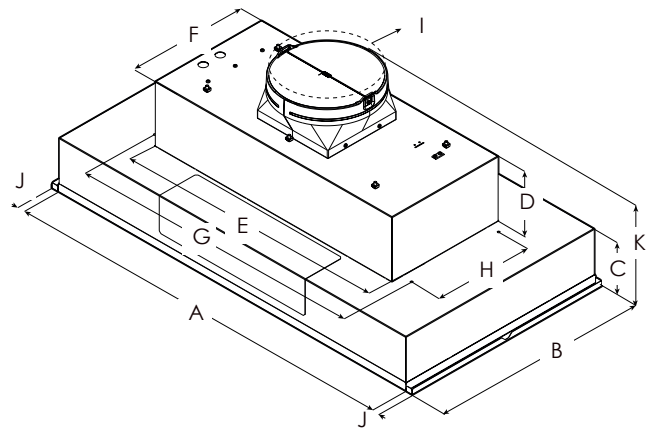





MOUNTING HEIGHT RANGE

	ESC628SS	ESC134SS	ESC146SS
A	28 1/2" (87.5 cm)	34 1/2" (87.5 cm)	46 1/2" (118.5 cm)
B	15 5/8" (39.8 cm)		
C	5 7/8" (13.8 cm)		
D	6 1/2" (16.4 cm)		
E	22 3/4" (56 cm)	27 7/8" (70 cm)	
F	12 7/8" (31.6 cm)		
G	24 23/64" (62 cm)	29 13/16" (75.7 cm)	
H	10 1/8" (25.7 cm)		
I	10" (25.4 cm)		
J	3/4" (1.9 cm)		
K	16 11/16" (42.4 cm)		

Width:	28" Unit	34" Unit	46" Unit
Model:	ESC628SS	ESC134SS	ESC146SS
Dimensions:	28 1/2"W x 15 5/8 "D x 11 15/16"H	34 1/2"W x 15 5/8 "D x 11 15/16"H	46 1/2"W x 15 5/8 "D x 11 15/16"H
Blower Type (Internal):**	600 CFM (4-speed)	1200 CFM (4-speed)	1200 CFM (4-speed)
Nois (sones):**	7.0 Sones	8.5 Sones	8.5 Sones
Finish:	Stainless Steel		
Controls:	Fully retractable rotating knobs with blue backlighting		
Illumination:	2 LED, 7.5 W 3000 Kelvin, 540 lumen		4 LED, 7.5 W 3000 Kelvin, 540 lumen
Grease Filter:	Dishwasher-Safe, Professional Stainless Steel Baffle Filters 2 for 28",34" & 3 for 46"		
Duct Transition:	10" Round with BackDraft Damper (top only)		
Installation Type:	Ducted Installation Only		
Electrical:	120V - 60 Hz, 490 W	120V - 60 Hz, 913 W	
KITS:			
1200 CFM External Blower Kit:	KIT0153054		
1200 CFM Inline Blower Kit:	KIT0154387		
10" to 8" transition KIT:	KIT0185271		
Inline Blower Shell Kit:	KIT0179549 (for use with 1200 CFM blowers only)		
External Blower Shell Kit:	KIT0179547 (for use with 1200 CFM blowers only)		
Electronic CFM Reduction Bypass Kit:	KIT0185752 (for 600 CFM Blower),KIT0185099 (for 1200 CFM Blower)		
WARRANTY:***	Two (2) Years Parts & In-Home Labor. Earn an additional One (1) Year of Parts & In-Home Labor by registering on elica.com.		

PLUS FEATURES

- 
HUSH SYSTEM - An exclusive sound deadening technology that effectively reduces sound levels by over 35%
- 
PROFESSIONAL PERFORMANCE - Special features and high performances for models with aspiration capacity between 600 and 1200 CFM's
- 
STAINLESS STEEL BAFFLE FILTERS WITH GREASE COLLECTORS - Designed for high airflow cooking, the "S" shape design traps high volumes of grease
- 
HEAT GUARD - Senses extreme temperatures (>158 F°) and automatically adjusts the blower speed to HIGH
- 
SEAMLESS CRAFTSMANSHIP - Heavy gauge stainless steel "Seamless" construction that delivers refined elegance.